

GS08

OPERATION&INSTRUCTION MANUAL

(3kW~18kW)

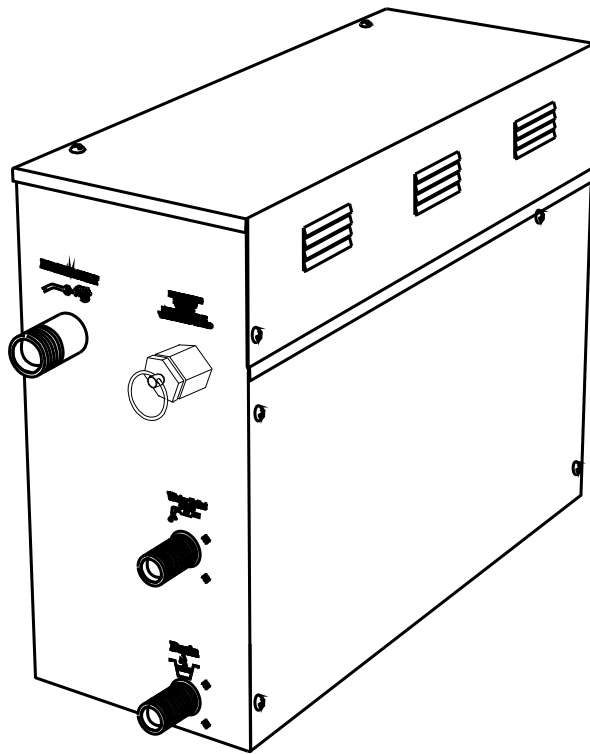

Cataloge

Prologue -----	1
Users instruction -----	1
The selection of the place of the steam equipment installation -----	1
The typical illustration of the steam equipment installation -----	2
Installation of the tube -----	3
Drawing of the steam generator -----	5
Electric requirements -----	6
Power line assemble illustration -----	8
Wiring Diagram 380-415V(3PH) -----	9
Wiring Diagram 208V(3PH) -----	10
Wiring Diagram 220-240V(1PH/2PH)-----	11
Installation of the top light -----	12
Choose your models -----	13
Maintenance of the stream generator -----	13
Steam generator structure drawing -----	14
Usual malfunction and resolve -----	15
Specification -----	16

Prologue

Welcome to use GS08 series steam generator, this series contains a steam furnace and a controller. You can adjust the temperature of the sauna room and set the working time of the steam as you wish. And the system contains an overheat/dry-burnt protection system and a security valve. It could prevent the overheating and assure the steam furnace working at a regular air pressure. It has the reasonable design and working very stable, very convenient to install, healthy and comfortable, is the top grade sauna equipment for the modern family, hotel, restaurant, meeting place and the club. You will be satisfied with the noticeable effects on pain relief, weight control, skin stimulation and stress reduction due to an increased blood circulation got from steam bath.

GS08 series include 9 types of machines that output power varies in 3kW, 4.5kW, 6kW, 7.5kW, 9kW, 10.5kW, 12kW, 15kW, 18kW, the users could choose it according to their requirements.

Users instruction

 **Caution:** *We are not responsible for the malfunction and damage came from the installation that not comply to the users manual.*

1. Make sure the model and the accessories are correct, include the voltage input.
2. Make sure the steam power are matched with the sauna room' dimension. Pay much attention to the steam room's cubage and construction. If you have any problem, please refer to the Page 11 about the dimension selection.
3. Make sure to read this manual carefully for the secure and effective use.
4. We shall not be responsible for the product damage or malfunction caused by self-installation or the operation procedures which is not operated by the users instructions.
5. GS08 series are packaged with a case, please check the goods when it arrived to assure it is in good condition, if you find any damage in the package, please contact the transportation company or the supplier to claim for compensation.
6. This product must be used indoor.

Choosing a right location

 **Important:** *Install an exhaust fan outside of the steam room in case that it can expel the excessive steam from the shower room.*

Some locations recommended to customers for the right installation.

1. The distance to the steam room less than 6m, the standard pipe which link the controller and the steam generator should be 6.5m.
2. The steam generator should not be installed in the steam room
3. Not installed outdoor or in any places that will influence the security of the machine by the environment.
4. Do not install it in the frigid loft or any places the water will freeze.
5. Do not install it near the burnable and caustic object or chemical (coal gas or dope thinner etc.)
6. Installed in a dry place and the ventilation is good.

7. Stable and horizontal. The steam generator has a hanging groove for immobility on wall. Make sure the machine is steady and horizontally installed.
8. On both sides and the top of the steam generator need to reserve at least 12 inches space.
9. The place where the machine is installed must be easily cleaned up and convenient for the disassembly of the machine.
10. The installation place must be convenient for the drain of water in inner pot.
11. The steam tube, safety valve, drain valve, water tube, steam outlet are still very heated after the steam generator have stopped working for some time. Must take some measures for example using the heat insulation tube to prevent the damage of the hot tube and keep the outlet away from the people.
12. The controller must be installed in the steam room, please refer to the chapter instruction of the controller's installation and operation of the manual.

Attention: *The steam generator (including the controller) are comply with the CE and UL certificate, and are adaptive in the moisture environment.*

Installation drawing of the steam generator

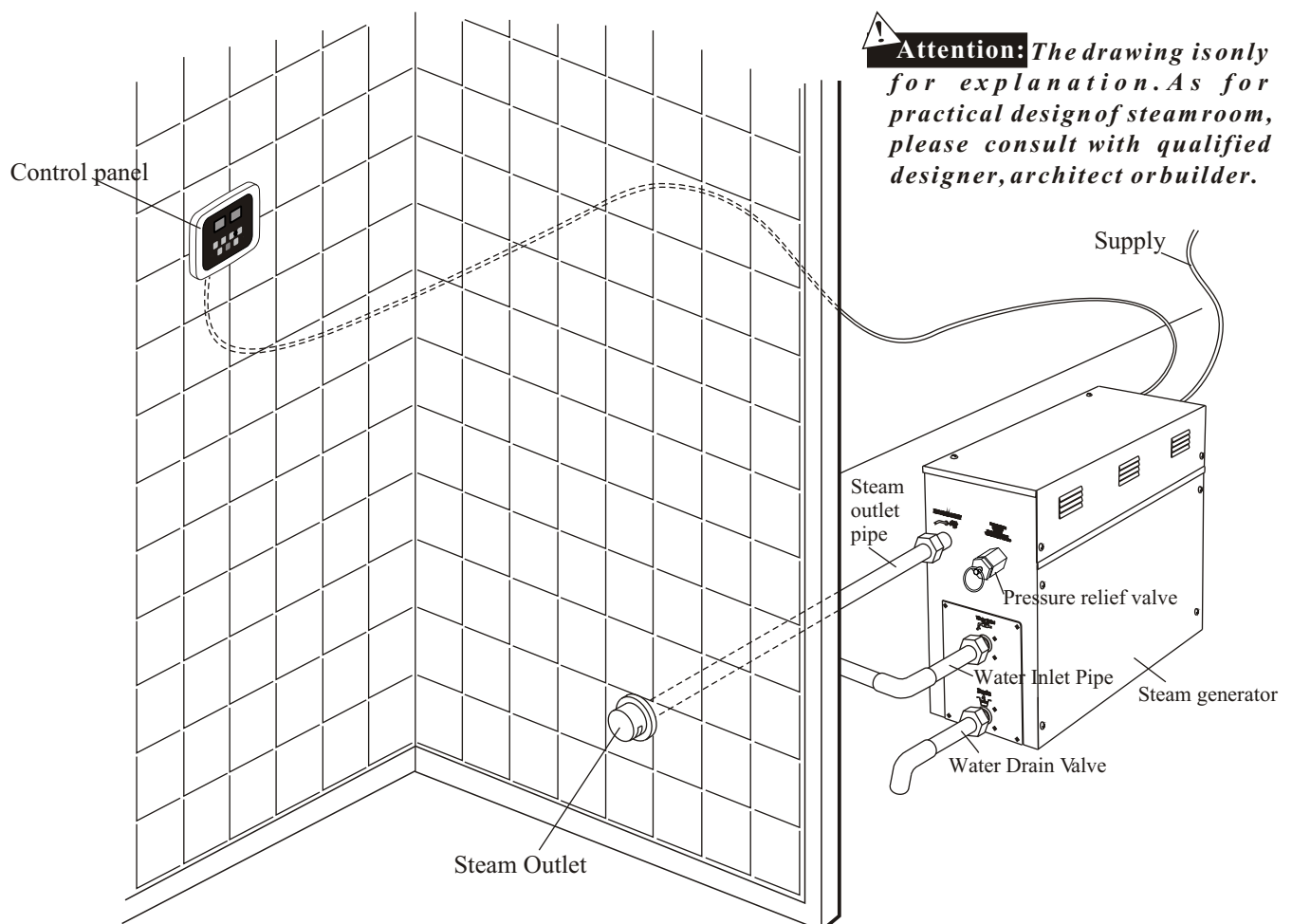

Installation of pipeline

Warning: *The installation of all the pipes should be operated by qualified plumbers with corresponding operation certificate in accordance with national requirements:*

1. Use joints when connecting pipes.
2. Use brass pipes or copper hoses only.
3. Do not use black and galvanized or PVC pipes.

Water supply pipe (1/2")

1. Connect hot water or cold water pipes. It had better be hot water pipe with a temperature no more than 70°C.
2. Install stop valve in the water supply pipe. The stop valve should be installed in a place where it is easily operated in emergency.
3. Clean the water supply pipe completely before connecting the water pipe to the steam engine.
4. It is suggested that filter and anti-furring equipment in the water supply pipe.
5. The water pressure should be at best between 15 and 20 pounds/square inch. If necessary, decrease the pressure accordingly.
6. If necessary, install equipment to prevent the water producing sound.

Steam pipe (3kW/4.5kW pipe size: 1/2", 6kw & above:3/4")

1. Do not install any valves in the steam pipes. The steam can never be obstructed.
2. Install a brass steam pipe (3kW/4.5kW pipe size: 1/2", 6kw & above:3/4") as connector between the steam outlet and the steam nozzle.
3. The heat insulation material used to insulate the steam pipe should be resistant to temperature as high as 120°C or higher.
4. The horizontal part of the steam pipe should be installed inclining to the steam outlet or in the direction of steam engine. Do not bend it in a hape to make sure that the cooled water will not stay in the curved pipe of the steam pipe.
5. The shorter the steam pipe, the better. Try to decrease the number of elbows and avoid abrupt turns.

Attention: *Do not install the steam pipe in an upper or lower direction now and then, which will affect the output of steam.*

Steam nozzle (3kW/4.5kW pipe size: 1/2", 6kw & above:3/4")

Attention: *Since the steam nozzle and steam outlet are very hot, try to avoid install the steam nozzle in the position which will easily come into contact with the person in a bath in case the steam should splash to scald the user.*

1. Install the steam nozzle in the position 6-12 inches above the ground. If the steam bath is in the bathtub or bathroom, install the steam nozzle 6 inches above the bathtub. If the steam room above adopts materials like acryl or non-heat-resistant sheet, install additional heat insulator.
2. The steam spray outlet should be installed face down. Wind a few circles of green material belt around the whorl of the steam pipe, install the steam nozzle and tighten with hands.

Attention: *In order to protect the steam nozzle, do not use the spanner or other tools to tighten, use a little soap water and soft sponge to wipe, and do not use erosive chemical solutions or crude cleaning tool.*

Important:

1. Please consult your distributors of building materials like acryl, fiber glass or other anti-heat sheet about the installation position of steam nozzle. It is suggested that MS-103412 anti-heat material can be used.
2. In the entire steam room, it is required that steam can not leak out. The pipes, its accessories and the holes in the wall should be airproof by applying airproof glue so that no steam will enter the holes in the wall.

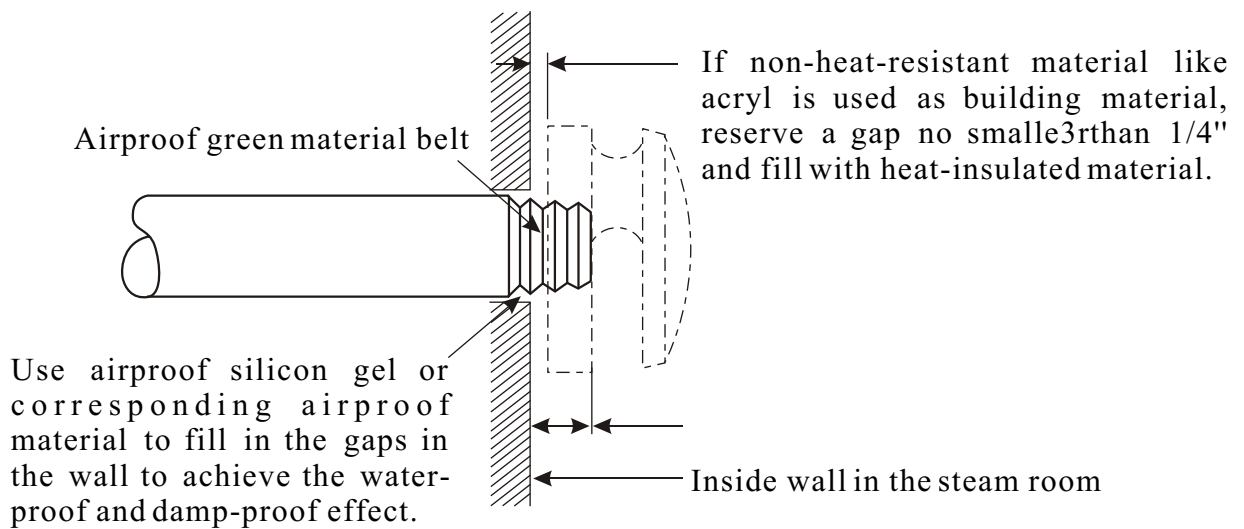

Drainpipe (1/2")

According to national or local rules, the steam engine drainage valve should be equipped with drainpipe. The steam engine drains the water by using weight.

Attention: *the drainpipe should not incline upwards so as to facilitate the drainage of water.*

Safety valve

1. Safety valve is a piece of safe equipment in order to prevent too much steam pressure in the interior steam engine due to various reasons.
2. The pressure limit range of safety valve is 15PSI and the pressure will begin to decrease if pressure should come over this value.
3. If it is allowed by local codes, provide the safety valve with exterior drainpipe.

Warning:

1. Do not dismantle the pressure decrease valve at random in case any danger should happen.
2. To maintain the proper and automatic operation of safety valve, make sure the safety valve connection pipe is smooth.

Blueprint for the steam engine

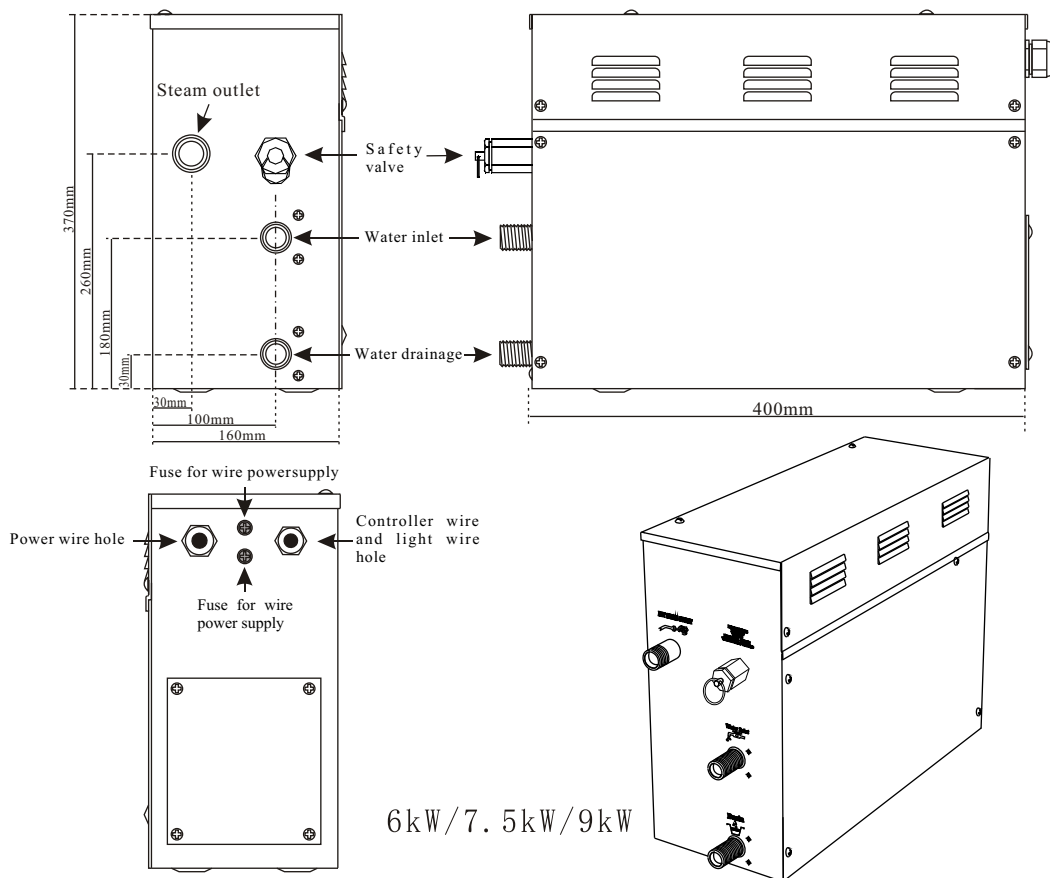
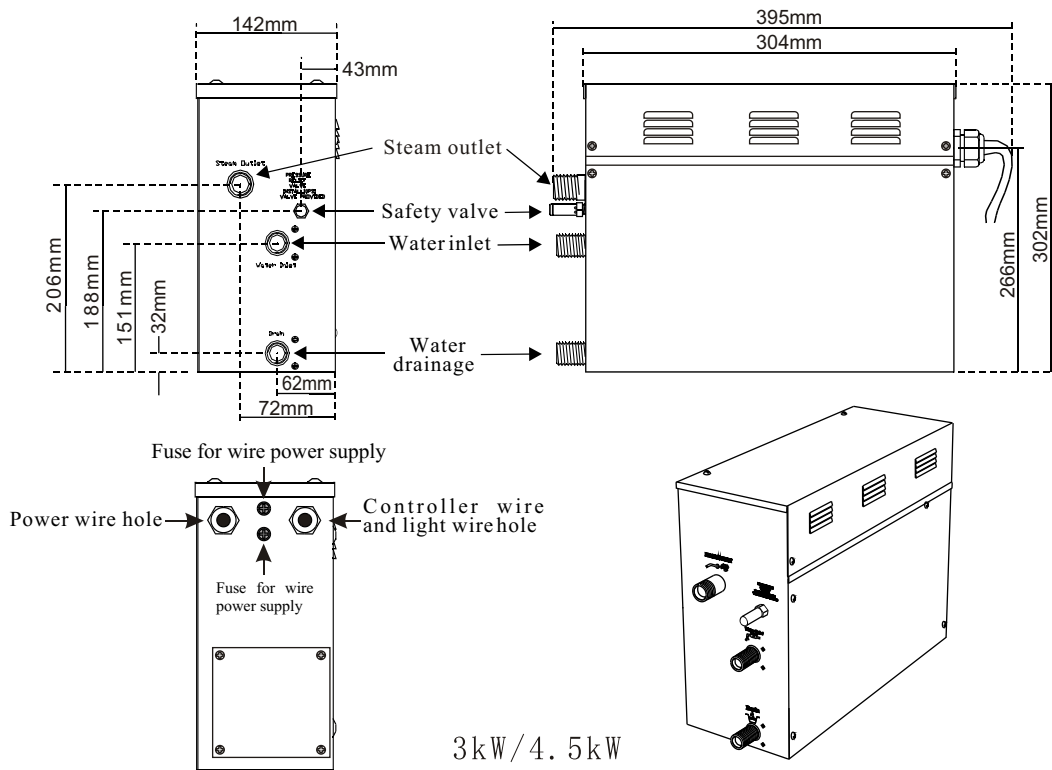

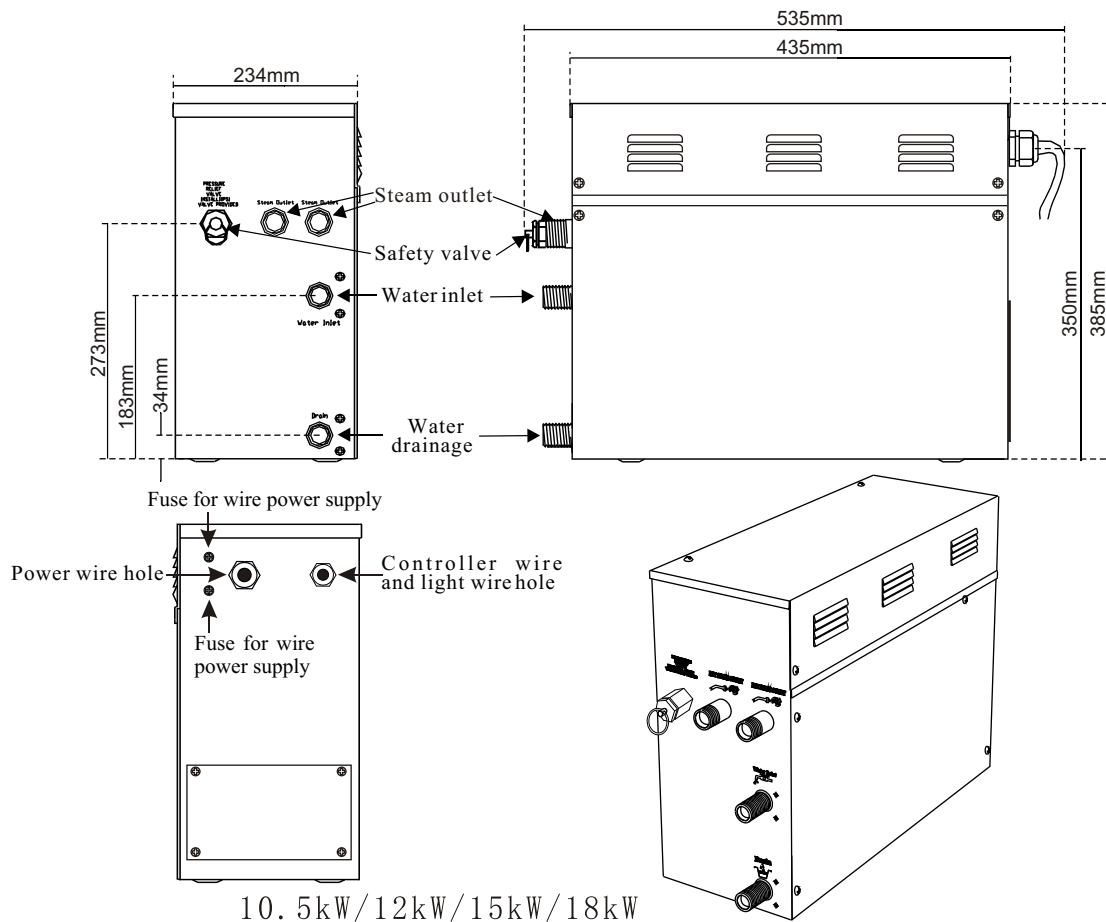

Attention: To facilitate maintenance, keep the steam engine clean. If the information provided is limited, do not operate on the pipeline and electric equipment arbitrarily as shown in the figure for proportion.

Caution: To avoid damage to the equipment, do not connect strong electric current directly to the components.

Electrical requirements:

Electricity supply circuitry:

1. Test the voltage of electricity supply and make sure steam engine with suitable electric voltage should be used.
2. Insulated copper wire should be used with an anti-heat temperature of 90°C and a specified voltage of 500V. Refer to national or local electricity consumption code for the specifications. Refer to the ammeter for the ampere.
3. Choose steam engine with suitable item number, and plug the ground wire into the ground terminal.
4. Install an independent circuit breaker between the power supply and the steam engine so as to provide an electricity supply with overflow protection and electricity leakage protection.

Attention: All the connection must be in accordance with national and local electricity consumption code and be installed by professional electricians.

Ampere Meter

Type	Applicable space of the room (m ³)	Electricity supply	Max. Electric current (A)	Specifications for power wire (AWG)
GS08-3kW	3~6	220-240V~(1PH/2PH)	13.7A	12# or 2.0mm ²
GS08-4.5kW	4~7	220-240V~(1PH/2PH)	20.5A	12# or 4.0mm ²
GS08-6kW	5~8	220-240V~(1PH/2PH)	27.3A	10# or 6.0mm ²
		208V~ (3PH)	16.7A	12# or 4.0mm ²
		380-415V~ (3PH)	9A	12# or 2.0mm ²
GS08-7.5kW	7~9	220-240V~(1PH/2PH)	34A	8# or 6.0mm ²
		208V~ (3PH)	21A	10# or 4.0mm ²
		380-415V~ (3PH)	11.4A	12# or 2.0mm ²
GS08-9kW	10~12	220-240V~(1PH/2PH)	41A	8# or 8.0mm ²
		208V~ (3PH)	25A	12# or 4.0mm ²
		380-415V~ (3PH)	13.7A	12# or 2.0mm ²
GS08-10.5kW	12~14	220-240V~(1PH/2PH)	48A	8# or 8.0mm ²
		208V~ (3PH)	29A	8# or 6.0mm ²
		380-415V~ (3PH)	16A	12# or 4.0mm ²
GS08-12kW	14~16	220-240V~(1PH/2PH)	55A	6# or 10.0mm ²
		208V~ (3PH)	33.3A	8# or 6.0mm ²
		380-415V~ (3PH)	18.2A	12# or 4.0mm ²
GS08-15kW	18~20	208V~ (3PH)	42A	6# or 8.0mm ²
		380-415V~ (3PH)	22.8A	12# or 4.0mm ²
GS08-18kW	20~24	208V~ (3PH)	50A	6# or 10.0mm ²
		380-415V~ (3PH)	27.3A	10# or 6.0mm ²

The data provided above are for 220-240V(1PH/2PH) and 208V(3PH) and 380-415V(3PH).

Within the eyeshot of the steam engine, install an independent circuit breaker so as to provide an electricity supply with overflow protection and electricity leakage protection.

Assembly graph for power wire

Attention: To avoid the damage to the equipment, do not connect strong electric current to the component directly.

Warning: This graph is for explanation only. For actual installation, refer to national and local electricity consumption codes by professional electricians.

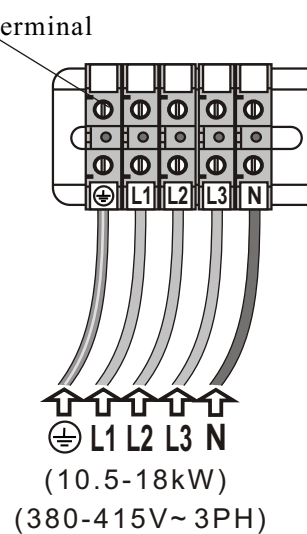
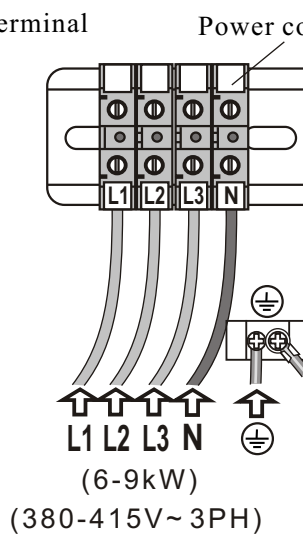
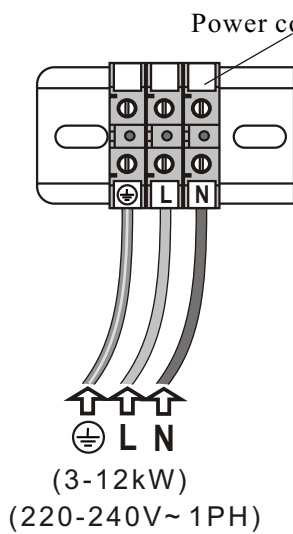
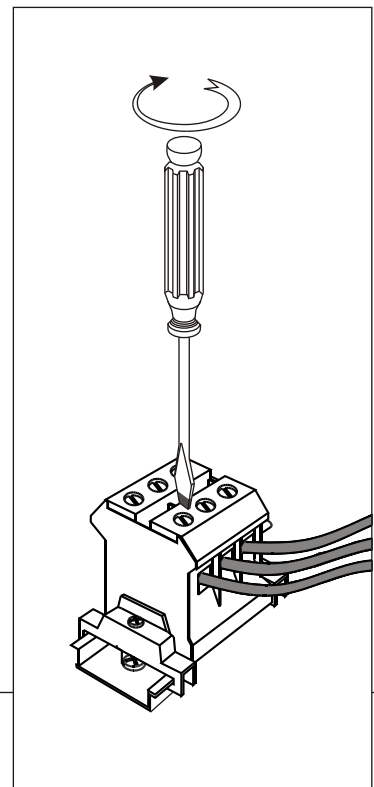
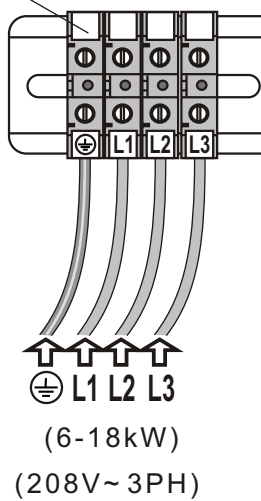
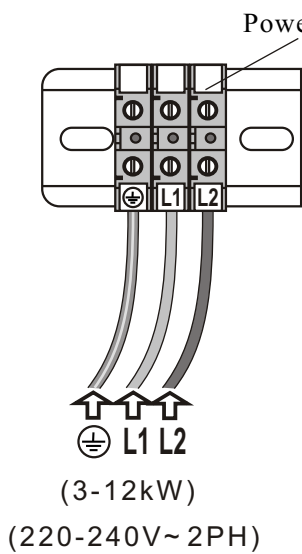

Wiring Diagram 380-415V(3PH)

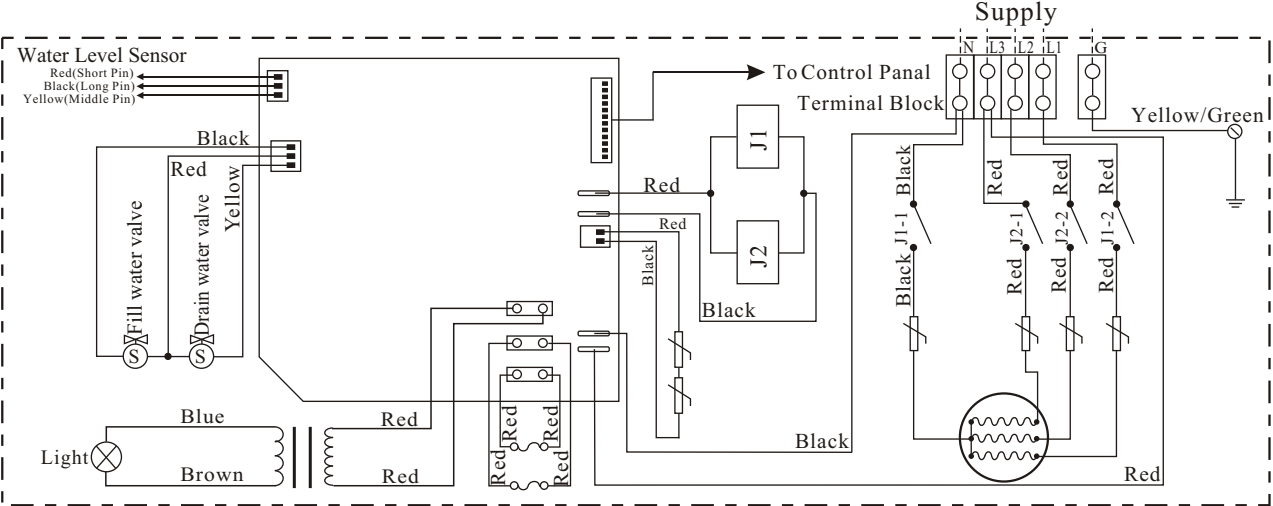

GS08-6kW/7.5kW/9kW (380-415V~3PH)

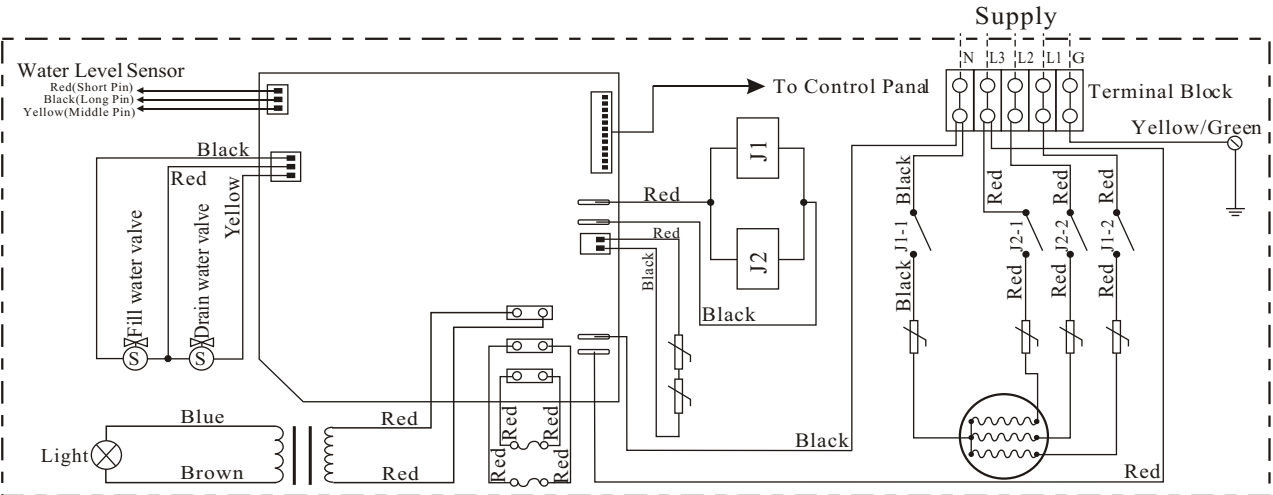

GS08-10.5kW/12kW/13.5kW (380-415V~3PH)

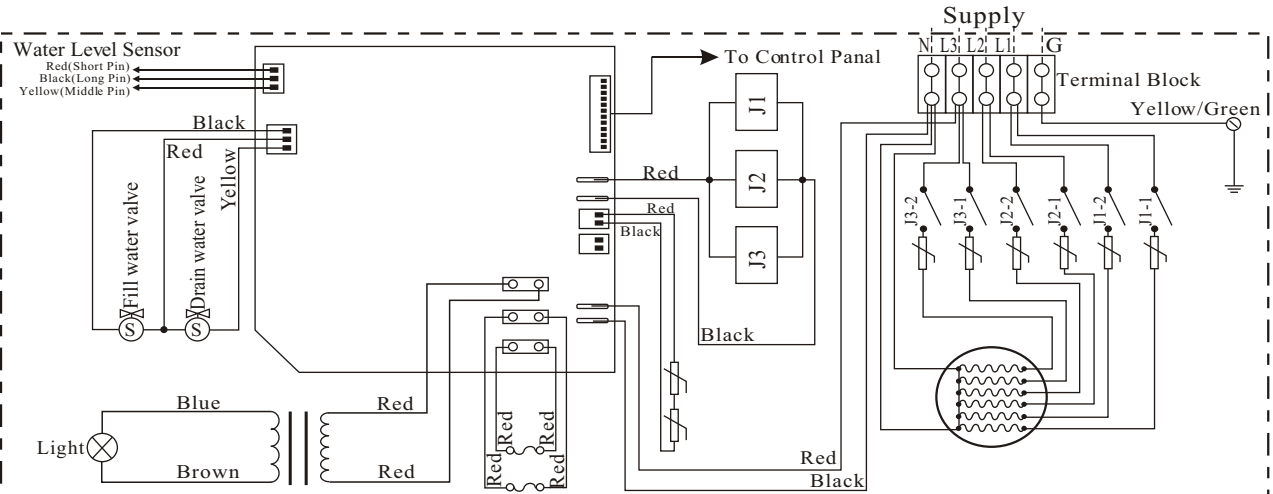

GS08-15kW/18kW (380-415V~3PH)

Wiring Diagram 208V (3PH)

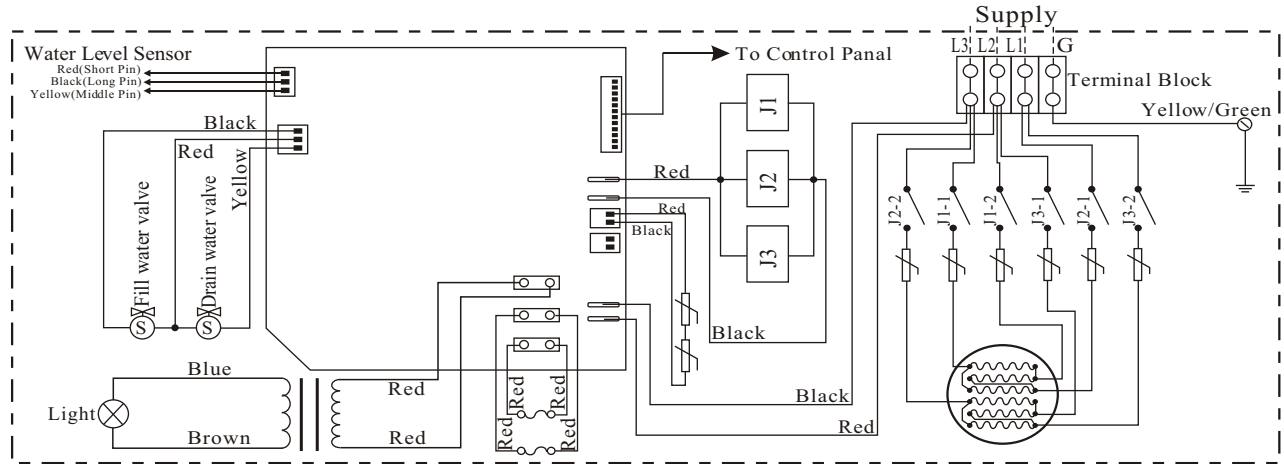

GS08-15kW/18kW (208V~3PH)

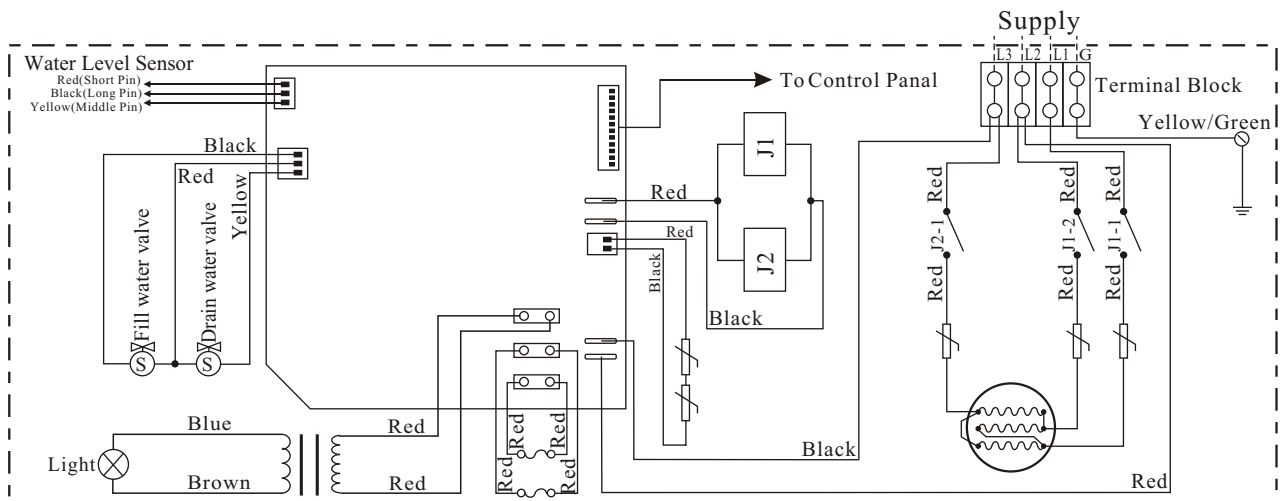

GS08-6kW/9kW (208V~3PH)

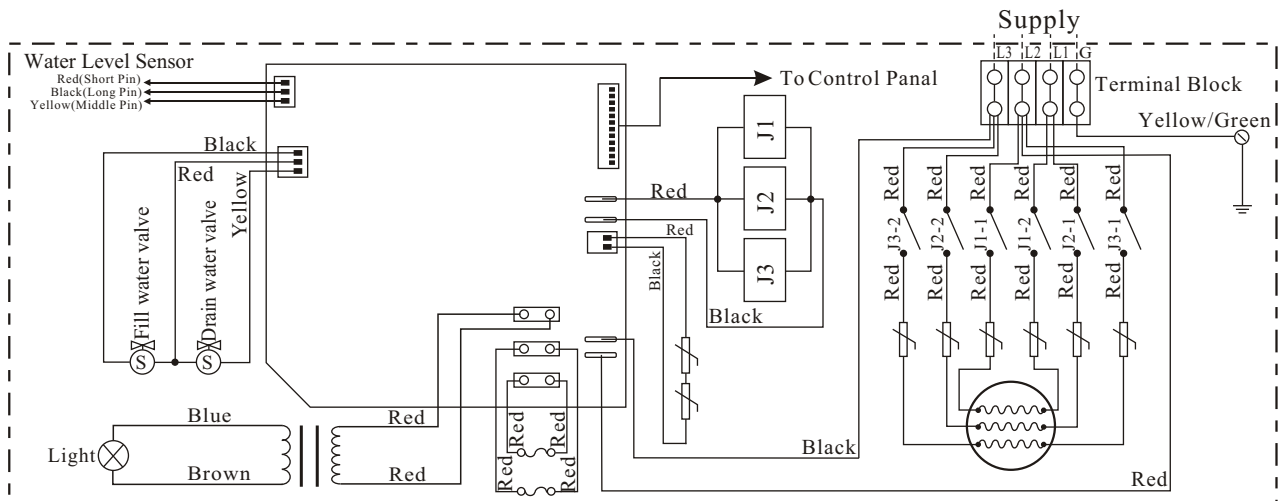

GS08-10.5kW/12kW/13.5kW (208V~3PH)

Wiring Diagram 220-240V(1PH/2PH)

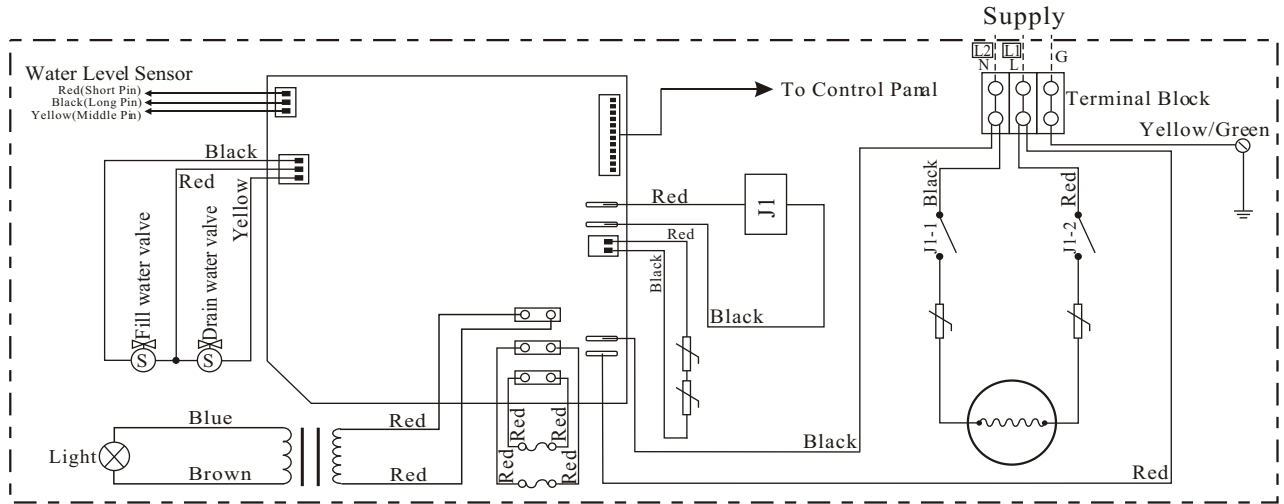

GS08-3kW (220-240V~ 1PH/2PH)

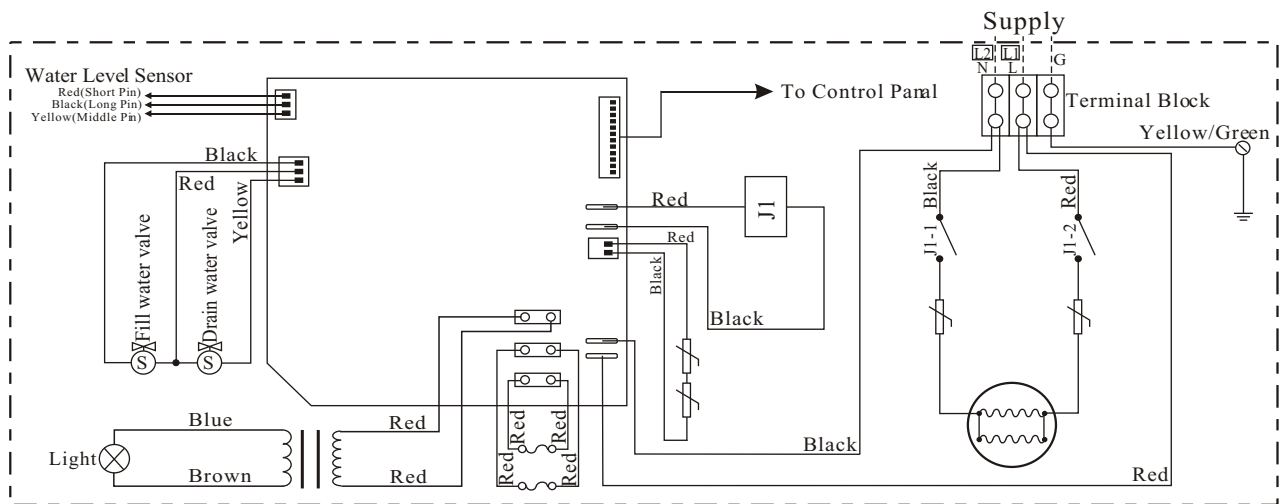

GS08-4.5kW (220-240V~ 1PH/2PH)

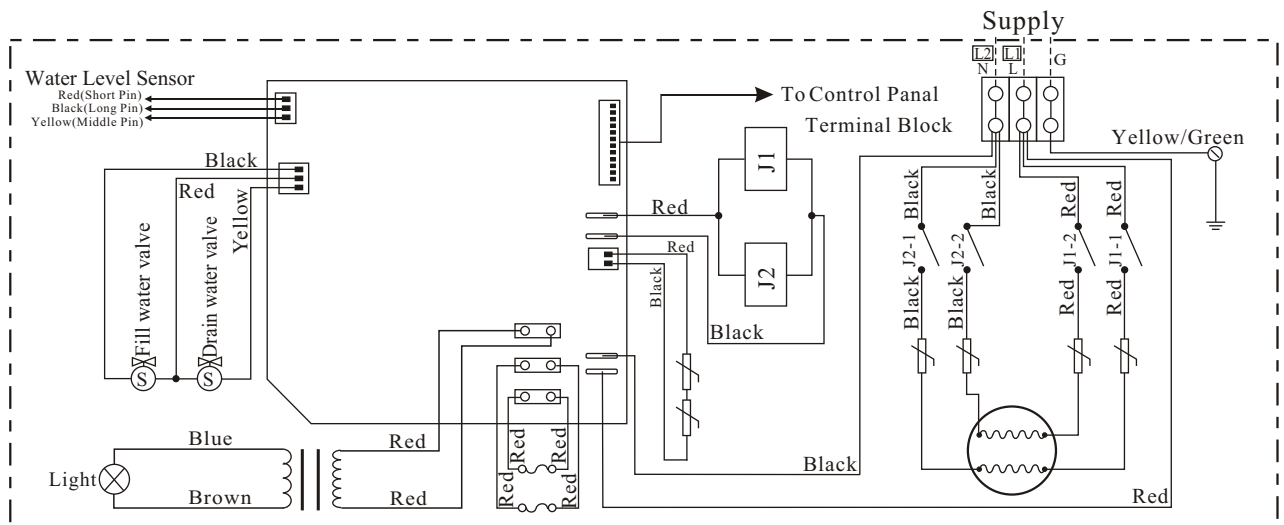

GS08-6kW/7.5kW/9kW (220-240V~ 1PH/2PH)

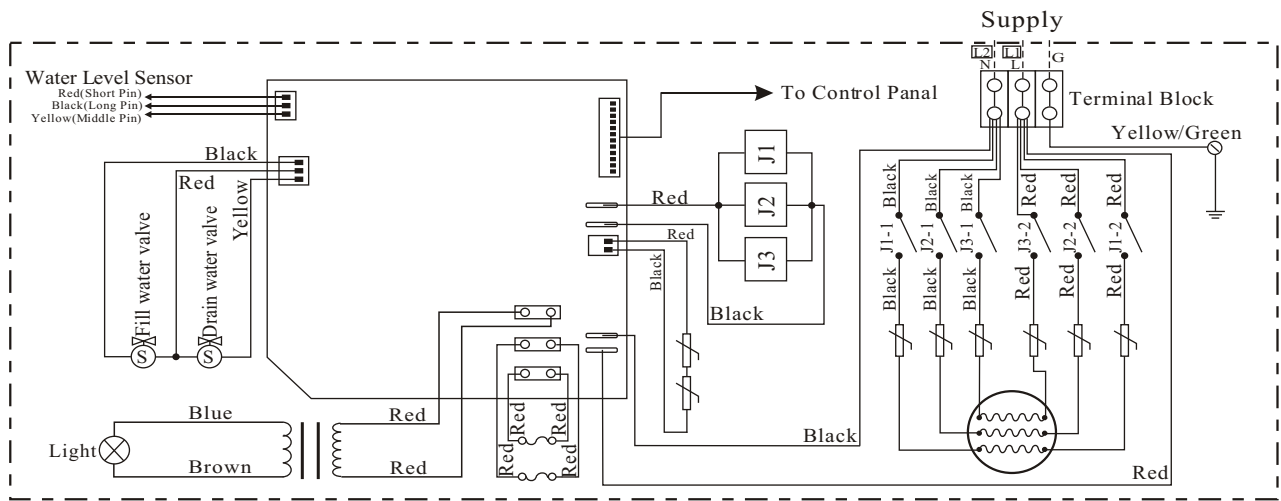

GS08-10.5kW/12kW (220-240V~ 1PH/2PH)

Installation of the top light

CAUTION:

Light is available in 12V/220V/230V outputs. Before connect to the light, please consult with manufacturer to know what voltage the light is, so as to avoid generator damage or cause danger.

If the light output is 12V, the power of the light should not be more than 35W, otherwise, transformer will be burned and cause danger. If light input is 220v~240V, light power should not more than 100W.

The light should be installed on the top of the steam room or the places where are not access to the children.

CAUTION: Take some moisture proof measures in process of installation. Can not let the electrical components be exposed to moisture or, it will cause damage or short circuit.

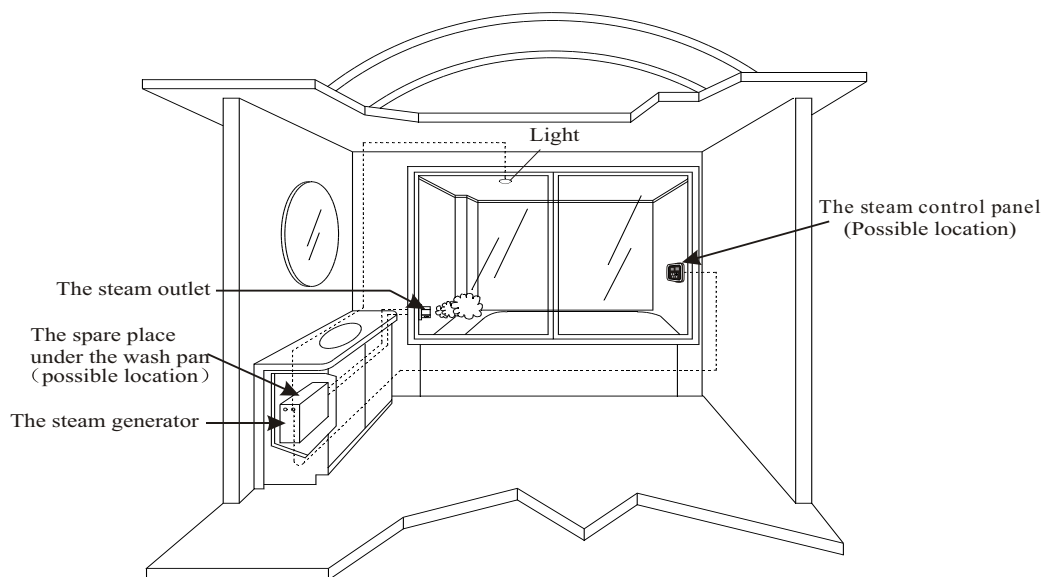

CAUTION: The illustration is just for explanation, the practical installation must comply with the nation's electric criterion, and processed by the professional electrician.

Choose your type of machine

Measure the length, width and height (foot) of the current steam shower or bathtub room.

Example;

L:7xW:5xH:8 = 280 Cubic Feet

You would need Model s-900(it is that simple)

However,if you shower materials are;

A:Natural Stone(Granite or Marble etc.)	ADD	75%
B:Exterior walls	ADD	25%
C:Celia Heights exceeding 8 FT.	ADD	25%
D:Ceramic tile	ADD	75%
E:Glass(2 walls)	ADD	75%

Important: *The calculation formula for selecting the type of steam engine is for reference only. Due to the variability of the building, the specifications and size illustration are used as guidelines only. If we have complete information, including actual blueprint, project instruction and building details, we can select the type of machine once again. Otherwise, the manufacturer will not be responsible for the selection of the type of machine.*

Maintenance of the steam engine

Important: *Perform water discharge operation after each use.*

1. Wait for the completion of automatic water discharge after each time of using the steam engine to make sure the water in the tank is discharged completely before cutting off power supply.
2. There should not be any leakage or damage among the steam engine, steam nozzle, components and pipes. They should be checked and repaired annually.
3. Clean the water supply pipes of the steam engine once a year.
4. Check all the connections, faucets and connection terminal to see whether they become loose or are damaged due to overheat.
5. Check the furring accumulated in the water tank and electric heating tube. If the furring is thick, dispose it in time (use diluted lemon acid to soak for 15-30 minutes).
6. Remove the water level sensory needle once a quarter to clean the furring in the needle.

Configuration of steam generator

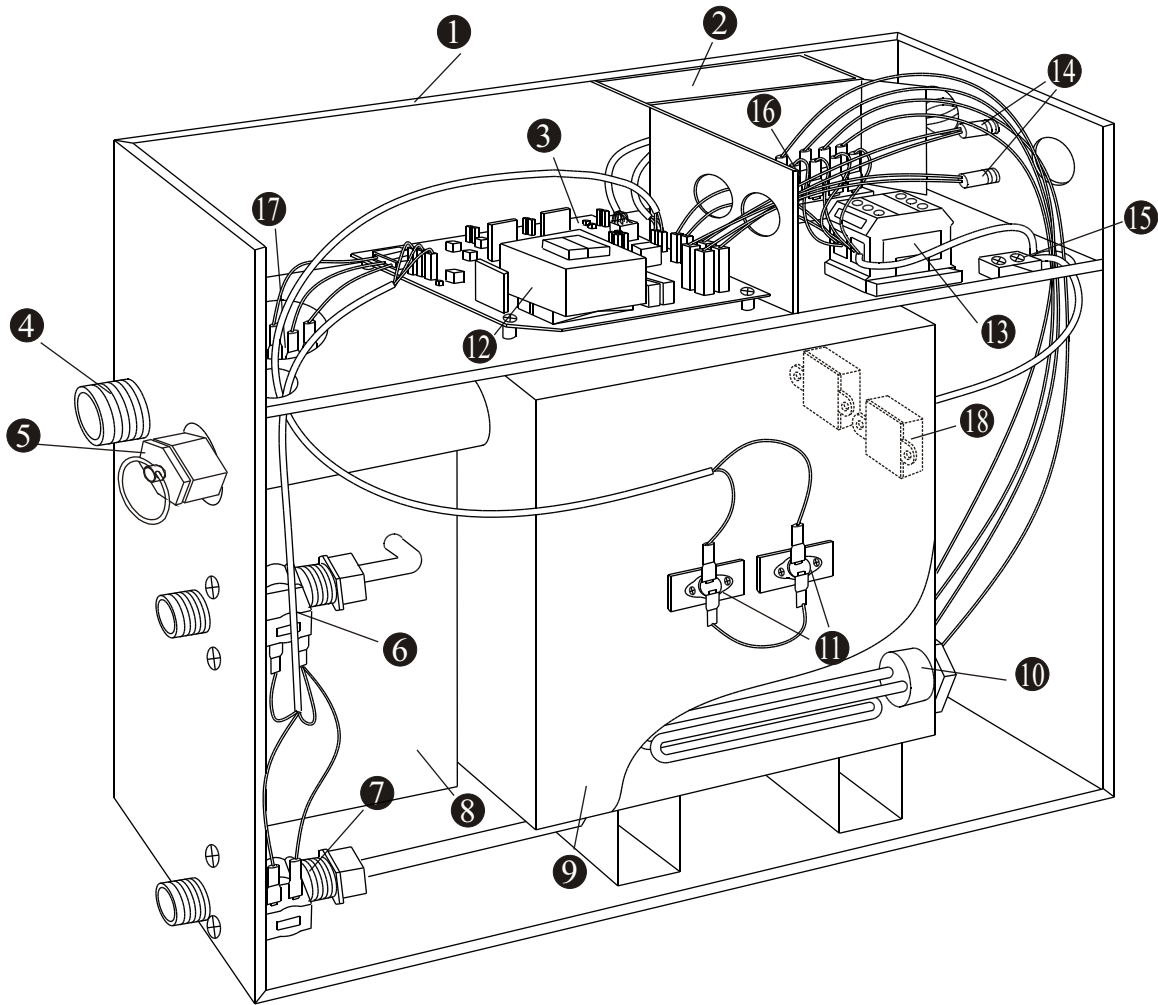

- | | | |
|-------------------------|-------------------------|------------------------|
| ① Enclosure | ⑦ Water drain valve | ⑬ Terminal block |
| ② Insulation bracket | ⑧ Subsidiary water tank | ⑭ Fuse |
| ③ Circuit board | ⑨ Main water tank | ⑮ Earth wire connector |
| ④ Steam Outlet | ⑩ Heating Element | ⑯ Relay |
| ⑤ Pressure relief valve | ⑪ 105°C Hi-limit | ⑰ Water level sensor |
| ⑥ Water fill valve | ⑫ Transformer | ⑱ 105°C Hi-limit |

Common troubles trouble shooting methods

To facilitate your use and maintenance of sauna room, the following common troubles trouble shooting methods are listed for identification.

Troubles	Causes of troubles	Trouble-shooting methods
The machine does not start when electrified	<ol style="list-style-type: none"> 1.The fuse is burned. 2.The wire connection terminal becomes loose. 3.Not good contact in the connection wire between the controller and the steam engine. 	<ol style="list-style-type: none"> 1.Change the fuse (on the shell 0.8A/250V) 2.Plug tight the wire connection terminal 3.Make sure the steam engine and the controller come into good contact
Electricity leakage switch breaks automatically	<ol style="list-style-type: none"> 1.The wire connector is dampened or damaged. 2.The heating tube breaks 	<ol style="list-style-type: none"> 1.Check whether the wire connector is dampened or damaged, and dry with dryer if dampened. 2.Change a heating tube.
When the machine is started, hot water comes out with little or no steam	<ol style="list-style-type: none"> 1. The water drainage valve is broken. 	<ol style="list-style-type: none"> 1. Change a water drainage valve.
The display screen on the control panel does not display	<ol style="list-style-type: none"> 1.The power wire is not connected well or not in good contact. The connection plug between the control panel and the electrically-controlled box becomes loose. 2.Trouble with plugboard. 	<ol style="list-style-type: none"> 1.Check whether the connection plug between the control panel and the electrically-controlled box has become loose, and whether the power circuitry has good contact 2.Change a plugboard.
Water leakage	<ol style="list-style-type: none"> 1.The water pipe connector becomes loose or the pipe breaks 2.Water leakage in the water input valve or the water drainage valve 	<ol style="list-style-type: none"> 1.Tighten the loose connector, and change the broken pipe. 2.Change the water input valve or the water drainage valve.
No steam when starting the machine	<ol style="list-style-type: none"> 1.No electricity. 2.No water. 3.The set temperature is too low 4.Trouble with wire. 	<ol style="list-style-type: none"> 1.Check the power supply 2.Check the water input pipe and water input valve 3.Reset the temperature 4.Contact the distributor
The steam does not come out, the water sounds in the machine	<ol style="list-style-type: none"> 1. The steam pipe is jammed. 	<ol style="list-style-type: none"> 1. Cut power supply to check whether the steam pipe is smooth.
The light can not be turned on	<ol style="list-style-type: none"> 1. The fuse is burned. 2. The light is broken 3. The wire is broken 4. The plug does not have good contact 	<ol style="list-style-type: none"> 1.Change the fuse (on the shell 1A/250V) 2. Change a light bulb. 3. Change wire. 4. Make the contact good.
The display box displays normally with no steam input	<ol style="list-style-type: none"> 1.Too much pressure inside the steam engine, so the system breaks for heat protection. 2.Wire is broken for heat protection. 	<ol style="list-style-type: none"> 1.Check the steam transport pipe and restore automatically after heat protection becomes cool. 2.Check the heat protection wire to make sure the connection is good.

⚠ Important: *The list above is for reference only. In actual checking and repairing, based on the national and local codes, ask professional service personnel to operate.*

Technical parameter

TYPE: GS08

Power Output	3kW	4.5kW	6kW	7.5kW	9kW	10.5kW	12kW	15kW	18kW
Potency Error	±10%	±10%	±10%	±10%	±10%	±10%	±10%	±10%	±10%
Duration	>1500V	>1500V	>1500V	>1500V	>1500V	>1500V	>1500V	>1500V	>1500V
Resistance	>20MΩ	>20MΩ	>20MΩ	>20MΩ	>20MΩ	>20MΩ	>20MΩ	>20MΩ	>20MΩ
Steam Pressure	0.12MPa	0.12MPa	0.14MPa	0.14MPa	0.14MPa	0.16MPa	0.16MPa	0.16MPa	0.16MPa
Steam Volume	140	160	180	220	260	300	360	450	500
Steam Production Time	100-150	90-120	100-160	90-140	80-130	180-240	150-160	120-150	90-150
Water Tank Volume	2.5L	2.5L	5.7L	5.7L	5.7L	12L	12L	12L	12L
Applicable space of the room (m³)	3~6	4~7	5~8	7~9	10~12	12~14	14~16	18~20	20~24

⚠ Important: *The parameter listed in the table will be varied from different place and temperature, please consultate to the qualificatory designer and architect for the more detailed use.*